

GUIDE TO MEASURING INDUSTRIAL WHEELS

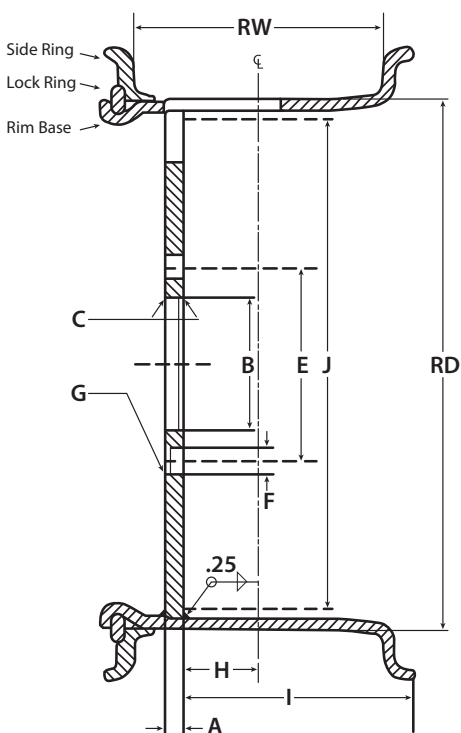

VEHICLE INFORMATION

Manufacturer: _____

Model No.: _____

Wheel Usage: Drive Steer Other

Tire Size: _____

Date of Manufacture: _____

Wheel Type:

- Lock Ring Style
- Split
- Press-On Hub
- Drop Center
- Other

	Inches	Metric
RW - Rim width:	_____	_____
RD - Rim Diameter:	_____	_____
A - Thickness of Disc:	_____	_____
B - Pilot Hole Diameter:	_____	_____
C - Pilot Hole Chamfer:		
Lock Ring Side	_____	_____
Fixed Flange Side	_____	_____
Break Edges Only (Standard)		
D - Number of Boltholes: _____		
E - Bolt Circle Diameter:	_____	_____
F - Bolthole Diameter:	_____	_____
G - Bolthole Chamfer:	Degrees	
Conical Front Side Major Diameter	_____	_____
Conical Back Side Major Diameter	_____	_____
Spherical Front Side Major Diameter	_____	_____
Spherical Back Side Major Diameter	_____	_____
Break Edges Only (Standard)		
H - Offset: The distance from the centerline (CL) of the rim to the mounting surface of the disc.		
- The offset on the wheel shown is positive (+H).		
- If the center disc is on the right side of the CL, the offset will be negative (-H).		
- If the center disc is exactly on the CL, the offset will be zero (H= 0).		
I - Backspacing: The distance from the innermost edge of the wheel to the disc's mounting surface.	_____	_____
Lock Ring: <input type="checkbox"/> Inboard <input type="checkbox"/> Outboard.		
J - Mounting Surface Machining: AWC's standard is to machine the mounting side of the disc up to the weld.		
Lock Ring Side Diameter	_____	_____
Fixed Flange Side Diameter	_____	_____